

# Wireless Door Bell

AVINASH RAJAK<sup>1</sup>, KUNAL PARKAR<sup>2</sup>, ANANYA SHETTY<sup>3</sup>, TARAKA PHADKE<sup>4</sup>  
PROF. DEEPIKA PATIL<sup>5</sup>

<sup>1-5</sup>Department of Electronics and Telecommunication  
K.C. College of Engineering & Management Studies & Research,  
Kopri, Thane (E)-400 603, India

*Abstract — Doorbells are usual signaling devices used to alert the person inside the house to open the door as someone has arrived. Classic doorbells can be seen in every house now a days, which uses simple button and when that button is pressed the bell rings. The doorbell which we are going to make is different from that. We will make a doorbell which is automatic, i.e. it will detect someone in front of it and then it will ring. Also, there is a flexibility that you can adjust the distance according to you by doing some changes in the code you are using to drive the doorbell. We will be using sensor to detect the person and then give the alert using a buzzer.*

## I. Introduction

Traditional Doorbell is wired devices and is usually fixed at one place. These types of wired doorbells were not very much reliable as this bell used to stop working at the time of electricity failures. The installation of wired doorbells is much complex when compared with the wireless doorbells. They are becoming obsolete because of these reasons wired doorbells are gradually being replaced by advanced Wireless Doorbell Device. By this type of bells, the installation and change for the position of bells will be easier and safer.

In this project, we are going to build a Wireless Doorbell using Arduino. We all know of the wired doorbell systems which require wires and suitable outlets for it to work satisfactorily. As the wired doorbell system needs complicated wiring. When it comes to installation, wireless doorbell system is very simple to install and requires no experience person for installation. By this type of devices there will be less consumption of electricity and it will be helping us in contribution of one of the major agenda in current time.

## II. LITERATURE SURVEY

According to paper “A Framework for Wireless Doorbell System with Object Detection” Door lock security systems are classified based on technology used as Password based, Biometric based, GSM based, smart card based, RFID based, Door phone based, Bluetooth based, social networking sites based, OTP based, Motion detector based.

The programmable electronic code lock device is programmed in such a way that it will operate only with the correct entry of predefined digits. The biometric technique is very useful in bank lockers. In many doorlock security systems, GSM is used for communication purpose. A model entryway security framework is intended to permit an authorized person for getting a safe (without need of any key) entryway. RFID Based Systems used for digital

door lock. In Door Phone Based System, visitors enter inside through the gate by controlling the gate with the help of the telephone set. Bluetooth based system is a bit like survey house innovations that utilizes Bluetooth function available in smart devices. In OTP Based Systems, the OTP is generated and sent to the proprietor's mobile phone whenever user requests to access facility.

### III. Block Diagram

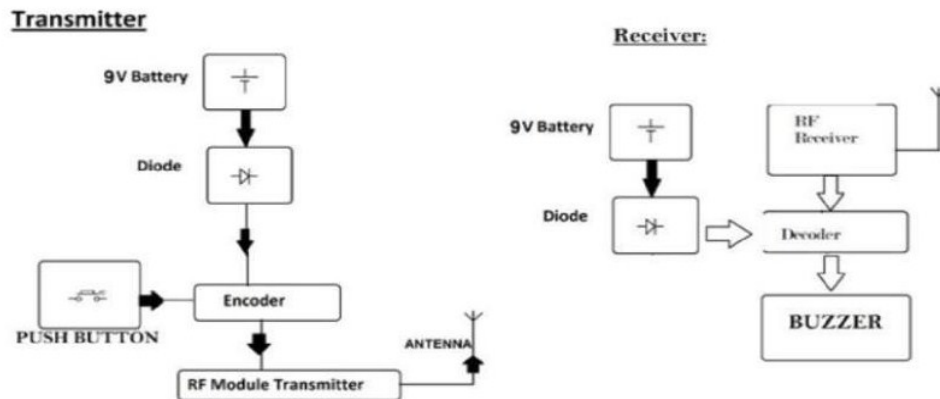

Figure 1. Wireless doorbell transmitter and receiver

Here in this transmitter section, 9V power supply is given to the circuit. When the person presses the push button of the transmitter circuit the signal will be sent to the encoder and then the encoder encodes the signal and then sends it to the RF Module Transmitter. The transmitter transmits the signal by using antenna. Now in the Receiver section here also 9V power supply is given to the circuit. In this circuit, the antenna receives the signal which is transmitted by the transmitter. Then this received signal is sent to the decoder and decodes the received signal and the buzzer rings.

The working of our project can be explained as when a person presses the button from the transmitter side the encoder IC sends the signal to the transmitter module and once the transmitter module receives the signal the signal is sent to the receiver module and over there the signal is sent to decoder IC which leads to the ringing of the bell. If the following steps are executed smoothly without any disturbance or faults so we can state that our project is successfully developed and can be used as our day-to-day application.

## IV. COMPONENTS LIST AND SPECIFICATION

### IV.1. 315 MHz RF Transmitter Module

It operates at a range of 3-12V which is also the power operating volts of most of the microcontrollers and boards. The module uses the ASK (Amplitude Shift Key) modulation method to transmits the data. It is one of the very low-cost power effective modules for both commercial, hobbyist, and developers. 433MHz Transmitter is one of the cheapest RF transmitters and it has a lot of applications and can be used interface with almost every microcontroller.



Figure 2. 315 MHz RF Transmitter Module

### IV.2. HT-12E Encoder IC

HT12E is an encoder integrated circuit of  $2^{12}$  series of encoders. They are paired with  $2^{12}$  series of decoders for use in remote control system applications. It is mainly used in interfacing RF and infrared circuits. The chosen pair of encoder/decoder should have same number of addresses and data format.



Figure 3. HT-12E Encoder IC

### IV.3. Push Button

A push-button or simply button is a simple mechanism to control some aspect of a machine or a process. Buttons are typically made out of hard material, usually plastic or metal. The surface is usually flat or shaped to accommodate the human finger or hand, so as to be easily depressed or pushed. Buttons are most often biased switches, although many un-biased buttons still require a spring to return to their un-pushed state.



Figure 4. Push Button

### IV.4. Power Supply (9V battery)

The nine-volt battery, or 9-volt battery, is an electric battery that supplies a nominal voltage of 9 Volts, actually 7.2 to 9.6 volts, depending on technology. Batteries of various sizes and capacities are manufactured; a very common size is known as PP3, introduced for early transistor radios.



Figure 5. Power Supply

#### IV.5. 315 MHz RF Receiver Module

The RF receiver delivers the output to the data pin in an encoded form. The operational voltage range of the module is 5V maximum. The frequency of the receiver can be changed using a node present on it. It is one of the popular and cheapest receivers and has low power consumption. 433MHz RF receiver module uses the ASK signal as an input.

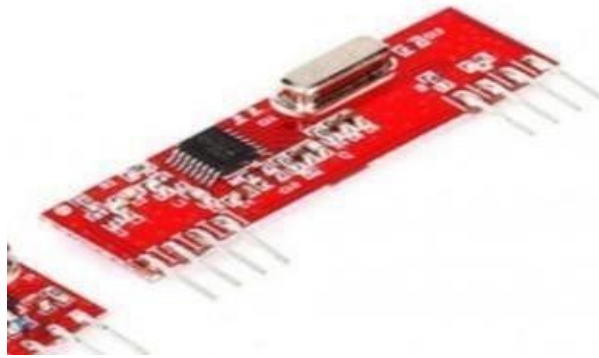

Figure 6. 315 MHz RF Receiver Module

#### IV.6. HT-12D Decoder IC

HT12D is a CMOS LSI IC and is capable of operating in a wide voltage range from 2.4V to 12V. Its power consumption is low and has high immunity against noise. The received data is checked 3 times for more accuracy. It has built in oscillator; we need to connect only a small external resistor.



Figure 7. HT-12D Decoder IC

### IV.7. Arduino UNO

The Arduino UNO is categorized as a microcontroller that uses the ATmega328 as a controller in it. The Arduino UNO board is used for an electronics project and is mostly preferred by beginners. The Arduino UNO board I type of Arduino board only. As the board can be easily connected to the other computer system via USB port the board is capable of getting the power supply from a DC adaptor having a voltage of 12 V. The board can be charged from this external power supply.



Figure 8. Arduino UNO

### IV.8. Buzzer

Rated Voltage: 6V DC

Operating Voltage: 4-8V DC

Rated current: <30mA

Sound Type: Continuous Beep Resonant Frequency: ~2300 Hz Small and neat sealed package Breadboard and Perfect board friendly



Figure 9. Buzzer

## IV. EXPECTED RESULTS

If the bell placed at the receiver end rings properly when a button is been pressed from the transmission end so we can conclude that our project is ready and is working smoothly.

## **V. CONCLUSION**

Wireless Doorbell increases the safety and security of your home as well as the comfort of your home. They give you the option of being able to speak with visitors through an intercom system without revealing where you are in your home.

## **VI. FUTURE SCOPE**

- i. In future, adaptive changes may be occurred in technology. It is motion sensor replacing switch.
- ii. We will also looking further for the addition of various sound effects to it and also a line of LED at the edge of the doorbell so that it look more of fascinating.

## **REFERENCES**

- [1] Ahmed Salad, Ahmed Muktar, AbdulAziz Ahmed, "A Framework for Wireless Doorbell System with Object Detection, " SOMALI JOURNAL OF ENGINEERING AND SCIENCE Vol. 2, Issue 1, July 2017.
- [2] Vicky Andrianson, "Advantages and Disadvantages of wireless Doorbell," The topDreamer publications, 2017.
- [3] Manoj Kumar, "Wireless Doorbell using Arduino and RF Module", – circuitdigest.com, 2019.